

MAXICRAWL®



PLAIN & GEARED CRAWLS

Crawls are easily adjustable to suit a wide range of beam widths & feature robust construction.



PLAIN

GEARED

Maxicrawl hoist crawls or trolleys are available in a push or hand geared versions. The hand chain fitted to the hand geared unit can be supplied to suit the height of lift required. The units can be adjusted to suit the width of any I-beam or H-beam. Extended shafts are available on request.

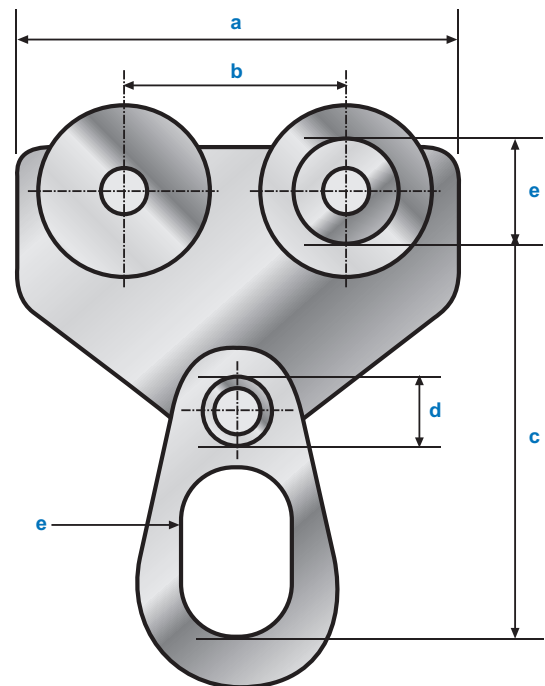

Dimensions		Capacity						
		1/2 Ton	1 Ton	2 Ton	3 Ton	5 Ton	10 Ton	20 Ton
Item Code	Plain	CRP005	CRP010	CRP020	CRP030	CRP050	CRP100	CRP200
	Geared	N/A	CRG010/3M	CRG020/3M	CRG030/3M	CRG050/3M	CRG100/3M	CRG200/3M
a	Overall Length	210mm	210mm	260mm	295mm	345mm	525mm	525mm
b	Distance Between Axles (Centre to Centre)	100mm	100mm	125mm	145mm	170mm	255mm	255mm
c	Distance Between Beam Base & Hook Bearing Point	145mm	145mm	135mm	170mm	195mm	210mm	250mm
d	Shaft Diameter	20mm	22mm	25mm	30mm	39mm	30mm	54mm
e	Load Wheel Diameter (At Load Bearing Surface)	54mm	54mm	80mm	105mm	115mm	200mm	200mm
f	Internal Width & Height of Suspension Eye	47mm	47mm	50mm	49x69mm	50x78mm	79x120mm	88x120mm

* Geared Code for 3m Hand Chain

Specifications		Capacity						
		1/2 Ton	1 Ton	2 Ton	3 Ton	5 Ton	10 Ton	20 Ton
Side Plate Thickness		8mm	10mm	10mm	12mm	16mm	20mm	30mm
Weight	Plain	8kg	9kg	15kg	25kg	40kg	139kg	N/A
	Geared	N/A	10kg	17kg	27.5kg	45kg	146kg	237kg
To Fit Beam Width	Minimum	76mm	76mm	92mm	92mm	125mm	138mm	145mm
	Maximum	138mm	138mm	152mm	152mm	191mm	230mm	305mm
Minimum Radius		1.3m	1.3m	1.5m	2.0m	2.5m	3.5m	3.5m